

Manta

G-419 NIR



- NIR enhanced sensor
- PoE option
- IEEE 1588 PTP
- Trigger over Ethernet
- Auto iris
- Angled head option
- Board level option

Simplify your setup of multi-camera applications

Modular machine vision camera with GigE Vision interface

Manta G-419 NIR with CMOSIS/ams CMV4000 NIR runs 28.0 frames per second at 4.2 MP resolution.

Manta is Allied Vision's most versatile GigE Vision camera series. It provides the largest choice of image sensors and its advanced feature set simplifies the setup of multi-camera applications. With its modular hardware concept, Manta offers nearly endless configuration possibilities to adapt the camera to your application.

Easy software integration with Allied Vision's [Vimba Suite](#) and compatibility to the most popular [third party image-processing libraries](#).

See the [Modular Concept](#) for lens mount, housing variants, optical filters, case design, and other modular options. See the [Customization and OEM Solutions](#) webpage for additional options.

Specifications

| | |
|------------------------------------|--|
| Interface | IEEE 802.3 1000BASE-T, IEEE 802.3af (PoE) optional |
| Resolution | 2048 (H) × 2048 (V) |
| Sensor | CMOSIS/ams CMV4000 NIR |
| Sensor type | CMOS |
| Shutter mode | Global shutter |
| Sensor size | Type 1 |
| Pixel size | 5.5 μm × 5.5 μm |
| Lens mounts (available) | C-Mount, CS-Mount, S-Mount |
| Max. frame rate at full resolution | 28 fps |
| ADC | 12 Bit |
| Image buffer (RAM) | 128 MByte |

Imaging performance

Imaging performance data is based on the evaluation methods in the EMVA 1288 Release 3.1 standard for characterization of image sensors and cameras. Measurements are typical values for NIR models measured at full resolution without optical filter. Contact Sales or AE for more information.

| | |
|--------------------------------|---------------------|
| Quantum efficiency at 529 nm | 77 % |
| Quantum efficiency at 850 nm | 40 % |
| Temporal dark noise | 9.5 e ⁻ |
| Saturation capacity | 9500 e ⁻ |
| Dynamic range | 60.0 dB |
| Absolute sensitivity threshold | 13.4 e ⁻ |

Output

| | |
|--------------------------|-----------------------------|
| Bit depth | 8/12 Bit |
| Monochrome pixel formats | Mono8, Mono12, Mono12Packed |

General purpose inputs/outputs (GPIOs)

| | |
|--------------------|---------------------|
| Opto-isolated I/Os | 2 inputs, 2 outputs |
| RS232 | 1 |

Operating conditions/dimensions

| | |
|-----------------------------------|---|
| Operating temperature | +5 °C to +45 °C ambient (without condensation) |
| Power requirements (DC) | 8 to 30 VDC AUX or IEEE 802.3af PoE |
| Power consumption | External power: 2.7 W at 12 VDC Power over Ethernet: 3.1 W |
| Mass | 190 g; 200 g (PoE) |
| Body dimensions (L × W × H in mm) | 86.4 × 44 × 29 (including connectors) |
| Regulations | CE: 2014/30/EU (EMC), 2011/65/EU, including amendment 2015/863/EU (RoHS); FCC Class B; CAN ICES-3 (B) |

Quantum efficiency

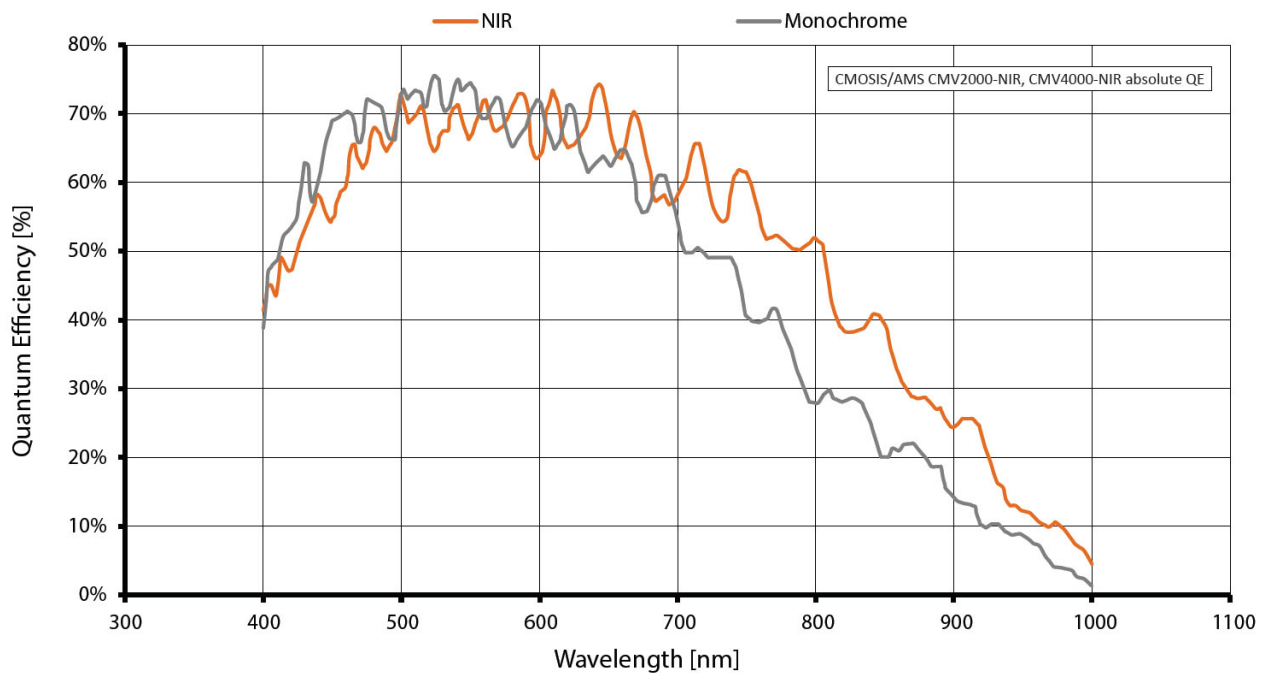

Features

Image control: Auto

- Auto exposure
- Auto gain

Image control: Other

- Black level
- Decimation
- DPC (defect pixel correction)
- Gamma
- LUT (look-up table)
- Reverse X/Y
- ROI (region of interest)

Camera control

- Acquisition frame rate
- Auto iris
- Bandwidth control
- Event channel
- Firmware update in the field
- I/O and trigger control
- Image chunk data
- PTP (IEEE 1588 Precision Time Protocol)
- Stream hold
- Temperature monitoring
- ToE (trigger over Ethernet, action commands)
- User sets

Technical drawing

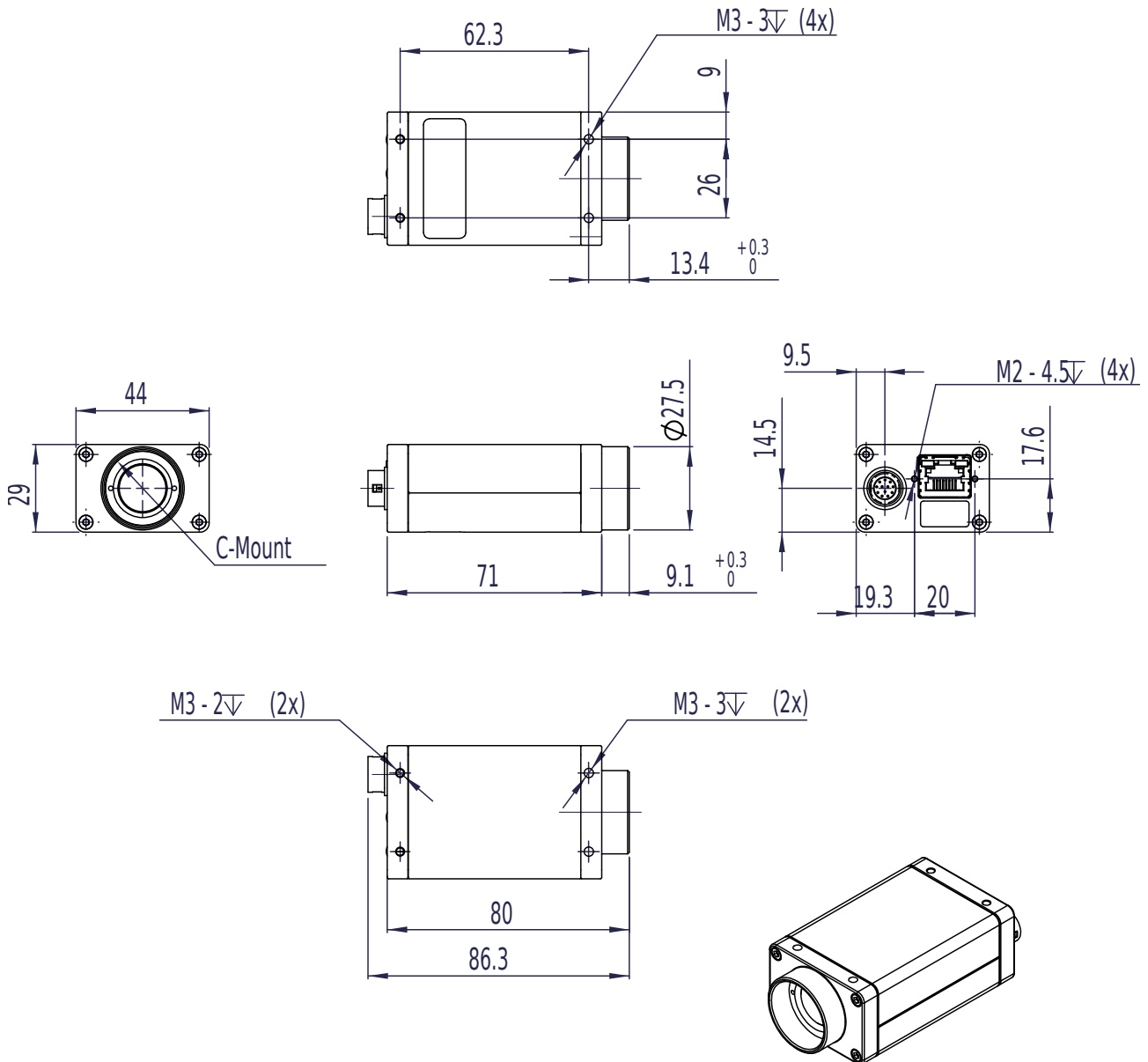

Applications

Manta G-419B NIR is ideal for a wide range of applications including:

- Multimedia and entertainment
- Machine vision
- Security and surveillance
- Metrology and inspection systems

- Industrial image processing